

Fisher-Price®

Please keep this instruction sheet for future reference, as it contains important information.

Requires three "AA" batteries (included) for operation.

Adult assembly is required.

Tool required for assembly: Phillips screwdriver (not included).



www.fisher-price.com

Parts

⚠ CAUTION

This package contains small parts in its unassembled state. Adult assembly is required.



Handle



Mower Base



Cap - 2



#6 x 3/4" (1.9 cm) Screw - 2
Shown Actual Size

Before Use

Note: A plastic tab is attached to the toy for in-store demonstration purposes. While the tab may have already been removed, check the bottom of the toy to be sure. If the plastic tab is still attached, pull and remove the tab. Throw the plastic tab away.

Assembly

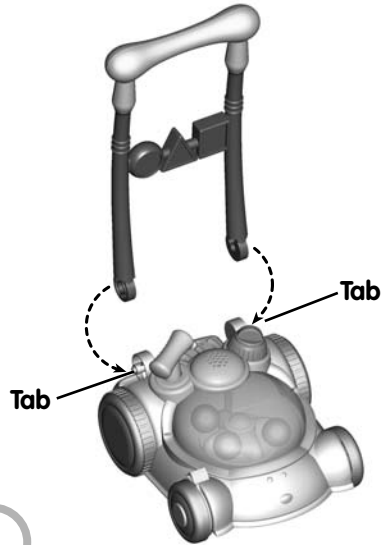

1

- Fit the ends of the handle onto the tabs on each side of the mower base.

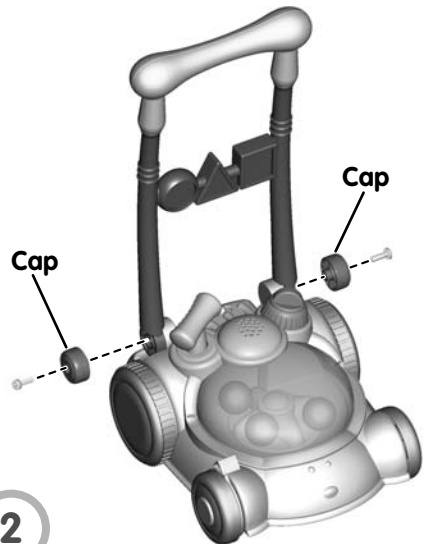

2

- Fit a cap onto each side of the handle.
- Insert a screw into each cap and tighten the screw with a Phillips screwdriver. Do not over-tighten.

Battery Replacement

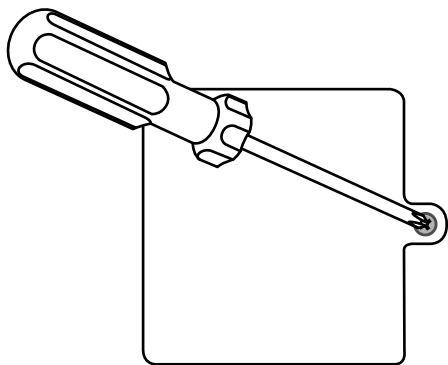

For best performance, we recommend replacing the batteries that came with this toy with three, new “AA” (LR6) alkaline batteries.

- Loosen the screw in the battery compartment door with a Phillips screwdriver. Remove the battery compartment door.
 - Insert three, new “AA” (LR6) **alkaline** batteries.
- Hint:** We recommend using **alkaline** batteries for longer battery life.
- Replace the battery compartment door and tighten the screw with a Phillips screwdriver. Do not over-tighten.
 - If this product begins to operate erratically, you may need to reset the electronics. Slide the power/mode switch off and then back on.
 - When sounds or lights from this toy become faint or stop, it's time for an adult to change the batteries!

Battery Safety Information

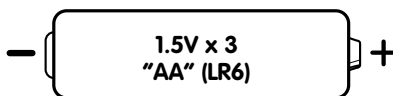

In exceptional circumstances, batteries may leak fluids that can cause a chemical burn injury or ruin your product. To avoid battery leakage:

- Do not mix old and new batteries or batteries of different types: alkaline, standard (carbon-zinc) or rechargeable (nickel-cadmium).
- Insert batteries as indicated inside the battery compartment.
- Remove batteries during long periods of non-use. Always remove exhausted batteries from the product. Dispose of batteries safely. Do not dispose of this product in a fire. The batteries inside may explode or leak.
- Never short-circuit the battery terminals.
- Use only batteries of the same or equivalent type, as recommended.
- Do not charge non-rechargeable batteries.
- Remove rechargeable batteries from the product before charging.
- If removable, rechargeable batteries are used, they are only to be charged under adult supervision.

Consumer Information



CONSUMER ASSISTANCE

1-800-432-5437 (US & Canada)
1300 135 312 (Australia)

service.fisher-price.com

Fisher-Price, Inc., 636 Girard Avenue, East Aurora, NY 14052.
Hearing-impaired consumers: 1-800-382-7470.

Outside the United States:

Canada: Mattel Canada Inc., 6155 Freemont Blvd.,
Mississauga, Ontario L5R 3W2; www.service.mattel.com.

Great Britain: [Mattel UK Ltd, Vanwall Business Park,
Maidenhead SL6 4UB](http://MattelUKLtd.VanwallBusinessPark.MaidenheadSL64UB). Helpline: 01628 500303.
www.service.mattel.com/uk

Australia: Mattel Australia Pty. Ltd., 658 Church Street,
Locked Bag #870, Richmond, Victoria 3121 Australia.

New Zealand: 16-18 William Pickering Drive,
Albany 1331, Auckland.

- Wipe this toy with a clean cloth dampened with a mild soap and water solution. Do not immerse this toy.
- This toy has no consumer serviceable parts. Do not take this toy apart.



- Protect the environment by not disposing of this product with household waste (2002/96/EC). Check your local authority for recycling advice and facilities (Europe only).

Consumer Information

FCC Statement (United States Only)

This equipment has been tested and found to comply with the limits for a Class B digital device, pursuant to Part 15 of the FCC Rules. These limits are designed to provide reasonable protection against harmful interference in a residential installation. This equipment generates, uses and can radiate radio frequency energy and, if not installed and used in accordance with the instructions, may cause harmful interference to radio communications. However, there is no guarantee that interference will not occur in a particular installation. If this equipment does cause harmful interference to radio or television reception, which can be determined by turning the equipment off and on, the user is encouraged to try to correct the interference by one or more of the following measures:

- Reorient or relocate the receiving antenna.
- Increase the separation between the equipment and receiver.
- Consult the dealer or an experienced radio/TV technician for help.

Note: Changes or modifications not expressly approved by the manufacturer responsible for compliance could void the user's authority to operate the equipment.

This device complies with Part 15 of the FCC Rules. Operation is subject to the following two conditions: (1) this device may not cause harmful interference and (2) this device must accept any interference received, including interference that may cause undesired operation.





ICES-003

This Class B digital apparatus complies with Canadian ICES-003. Operation is subject to the following two conditions: (1) this device may not cause harmful interference and (2) this device must accept any interference received, including interference that may cause undesired operation.

NMB-003

Cet appareil numérique de la classe B est conforme à la norme NMB-003 du Canada. L'utilisation de ce dispositif est autorisée seulement aux conditions suivantes: (1) il ne doit pas produire de brouillage et (2) l'utilisateur du dispositif doit être prêt à accepter tout brouillage radioélectrique reçu, même si ce brouillage est susceptible de compromettre le fonctionnement du dispositif.

Let's Get Mowin' with Music and Fun!

- Slide the **power/mode switch** to Learning Mode **ABC**, Music Mode , or Imagination Mode .
- Slide the volume switch on the bottom of the product to high  or low  volume.

ABC Learning Mode

- Push the mower to hear phrases or a learning song.
- Push or pull the handle to learn opposites.
- Turn the dial to learn counting or hear phrases.

Music Mode

- Push the mower for a fun song.
- Push or pull the handle or turn the dial to hear musical ditties.

Imagination Mode

- Push the mower to hear realistic mower sounds.
- Push or pull the handle and hear the sounds of a mower starting up or shutting off.
- Turn the dial for another fun sound effect.
- When your child is finished playing with this toy, slide the power/mode switch OFF .

